

Version 2.1

May 2007

L-ACOUSTICS P SERIES

I08P, I12P, SB15P

OPERATOR MANUAL



IMPORTANT SAFETY INSTRUCTIONS



The Lightning Flash with arrowhead symbol within an equilateral triangle is intended to alert the user to the presence of uninsulated "dangerous voltage" within the product's enclosure that may be of sufficient magnitude to constitute a risk of shock to persons.



The exclamation point within an equilateral triangle is intended to alert the user to the presence of important operating instructions in the literature accompanying the product.



WARNING: TO REDUCE THE RISK OF FIRE OR ELECTRIC SHOCK, DO NOT EXPOSE THIS APPARATUS TO RAIN OR MOISTURE AND OBJECTS FILLED WITH LIQUIDS, SUCH AS VASES, SHOULD NOT BE PLACED ON THIS APPARATUS.

1. Read these instructions.
2. Keep these instructions.
3. Heed all warnings.
4. Follow all instructions.
5. Do not use this apparatus near water.
6. Clean only with dry cloth.
7. Do not block any ventilation openings. Install in accordance with the manufacturer's instructions.
8. Do not install near any heat sources such as radiators, heat registers, stoves or other apparatus (including amplifiers) that produce heat.
9. Do not defeat the safety purpose of the grounding-type plug. A grounding type plug has two blades and a third grounding prong. The third prong is provided for your safety. If the provided plug does not fit into your outlet, consult an electrician for replacement of the obsolete outlet.
10. Protect the power cord from being walked on or pinched particularly at plugs, convenience receptacles and the point where they exit from the apparatus.
11. Only use attachments / accessories specified by the manufacturer.



12. Use only with the cart, stand, tripod, bracket, or table specified by the manufacturer, or sold with the apparatus. When a cart is used, use caution when moving the cart/apparatus combination to avoid injury from tip-over.

13. Unplug this apparatus during lightning storms or when unused for long periods of time.
14. Refer all servicing to qualified service personnel. Servicing is required when the apparatus has been damaged in any way, such as power-supply cord or plug is damaged, liquid has been spilled or objects have fallen into the apparatus, the apparatus has been exposed to rain or moisture, does not operate normally or has been dropped.
15. Since the mains power supply cord attachment plug is used as disconnect device, the plug should always be easily accessible.
16. Fire ignition sources such as candles should not be placed on the product or in close proximity to the product.

- Operating temperature: 0°C to 35°C
- Operating mains voltage: 95VAC-125VAC (@115V voltage selector position), 195VAC-250VAC (@230V voltage selector position)



Before applying AC power, ensure that the voltage selector is correctly set for the mains power source (115 V or 230 V) and that the fuse has the appropriate rating.

FOREWORD

Thank you for purchasing the I08P, I12P or SB15P self-powered loudspeaker system.

This manual is intended to provide you with the information you require to effectively install and operate your P series loudspeaker in a variety of professional sound reinforcement applications.

We are confident that the information provided in this manual will be sufficient for most applications, however, should you require further assistance your distributor or L-ACOUSTICS® are available to provide additional technical support.

MANUAL ORGANIZATION

- ◆ The Introduction gives a brief presentation of coaxial technology and the P series.
- ◆ Chapter 1 introduces I08P , I12P and SB15P loudspeakers plus accessories
- ◆ Chapter 2 describes cabling and connections
- ◆ Chapter 3 discusses P Series applications
- ◆ Chapter 4 details I08P, I12P and SB15P installation procedures
- ◆ Chapter 5 outlines P Series loudspeaker operation
- ◆ Chapter 6 provides I08P, I12P and SB15P specifications

TABLE OF CONTENTS

IMPORTANT SAFETY INSTRUCTIONS	1
FOREWORD	3
MANUAL ORGANIZATION	3
TABLE OF CONTENTS	4
TABLE OF CONTENTS	4
LIST OF FIGURES	5
1. THE P SERIES	6
1.1 OVERVIEW.....	9
1.2 108P, 112P SERIES PRESETS.....	12
1.3 SB15P PRESETS.....	13
1.4 108P DESCRIPTION.....	14
1.5 112P DESCRIPTION.....	15
1.6 SB15P DESCRIPTION	16
2. CONNECTORS and CABLES	18
3. APPLICATIONS	20
3.1 AIMING P SERIES ENCLOSURES.....	20
3.2 DISTRIBUTED SOUND REINFORCEMENT.....	21
3.3 108P NEARFIELD MONITORING.....	22
3.4 FLOOR MONITORING	22
4. INSTALLATION PROCEDURES	23
4.1 ETR8-2 U-BRACKET ATTACHMENT	23
4.2 ETR112XT U-BRACKET ATTACHMENT	24
4.3 XTLIFTBAR ATTACHMENT	25
4.4 ETR15P U-BRACKET ATTACHMENT.....	26
4.5 SAFETY RULES.....	27
5. P SERIES LOUDSPEAKER OPERATION	28
6. SPECIFICATIONS	29
6.1 108P SPECIFICATIONS.....	29
6.2 112P SPECIFICATIONS.....	32
6.3 SB15P SPECIFICATIONS	36
WARRANTY AND DISCLAIMERS	39
FACTORY SERVICE	39
APPROVALS	47

LIST OF FIGURES

Figure 1: I08P, I12P Loudspeaker Enclosures.....	6
Figure 2: SB15P self-powered subwoofer.....	7
Figure 3: P Series Rigging Components.....	8
Figure 4: I08P Enclosure.....	9
Figure 5: I12P Enclosure.....	10
Figure 6: SB15P Enclosure.....	11
Figure 7: I08P, I12P preset selector switch closeup and preset options.....	12
Figure 8: SB15P preset selector switch closeup.....	13
Figure 9: SB15P with positive polarity, I08P or I12P in X-OVER mode.....	13
Figure 10: SB15P with negative polarity, I08P or I12P in FRONT mode.....	13
Figure 11: I08P (floor monitor orientation).....	14
Figure 12: I12P (floor monitor orientation).....	15
Figure 13: SB15P (with pole-mounted I08P).....	17
Figure 14a: I08P / I12P DSP Power Amplifier Module Rear Panel.....	18
Figure 14b: SB15P DSP Power Amplifier Module Rear Panel.....	18
Figure 15: P Series mains power cables.....	18
Figure 16: Daisy-chain connection of P Series enclosures.....	19
Figure 17: Connecting unbalanced sources.....	19
Figure 18: General guidelines for aiming P Series enclosures.....	20
Figure 19: General guidelines for I08P or I12P enclosure spacing.....	21
Figure 20: ETR8-2 U-bracket installation procedure.....	23
Figure 21: ETRI12XT U-bracket installation procedure.....	25
Figure 22: XTLIFTBAR installation procedure.....	25
Figure 23: ETRI5P U-bracket installation procedure.....	26
Figure 24: I08P Line Drawing.....	30
Figure 25: I08P + ETR8-2 Line Drawing.....	31
Figure 26: I12P Line Drawing.....	32
Figure 27: I12P + ETRI12XT Line Drawing.....	34
Figure 28: I12P + XTLIFTBAR Line Drawing.....	35
Figure 29: SB15P Line Drawing.....	37
Figure 30: SB15P + ETRI5P Line Drawing.....	38

0. INTRODUCTION

The I08P and I12P combine the significant advantages of L-ACOUSTICS' proven coaxial point source technology with the convenience of self-powered performance and the power plus flexibility of on-board digital signal processing.

Designed for portable applications, the I08P and I12P are suitable for distributed sound reinforcement in theatre, congress centre, concert hall, trade show, corporate A/V, houses of worship, club, or television applications. When used with the L-ACOUSTICS SB15P self-powered subwoofer, the I08P and I12P can also be used for side fill, drum monitoring or small-to-medium format front-of-house (FOH) applications. In addition to these applications, the I08P is specifically optimized for use as a high-power nearfield monitor while the I12P provides a high-performance stage monitoring solution.

The L-ACOUSTICS approach to distributed sound reinforcement starts with the specification that each individual loudspeaker should behave as a coherent point source. This specification can be met using coaxial components due to the fact that the directivity of the low and high frequency (LF and HF) transducers is matched at the crossover frequency. This provides a smooth transition between LF and HF sections with power response that is free of the polar lobing effects typical of traditional horn / woofer combinations. In addition, coaxial component directivity is horizontally, vertically and diagonally symmetric (axi-symmetric), thus providing true point source behavior.

Extensive sound design and installation experience acquired by L-ACOUSTICS over the years confirms this and we are confident that coaxial, axi-symmetric loudspeaker enclosures are the best tools for multiple source, distributed sound reinforcement.

I. THE P SERIES

The L-ACOUSTICS P Series consists of: I08P and I12P self-powered loudspeaker enclosures, the SB15P self-powered subwoofer and I08P, I12P, SB15P rigging accessories.

LOUDSPEAKER ENCLOSURES

(1) I08P

Self-powered 2-way coaxial loudspeaker with 100-degree axi-symmetrical coverage, containing 8" loudspeaker, 1" exit high frequency compression driver

(2) I12P

Self-powered 2-way coaxial loudspeaker with 90-degree axi-symmetrical coverage, containing 12" loudspeaker, 1.4" exit high frequency compression driver



Figure I: I08P, I12P Loudspeaker Enclosures

SUBWOOFER ENCLOSURE

(3) SB15P

Self-powered 15" subwoofer enclosure



Figure 2: SB15P self-powered subwoofer

RIGGING ACCESSORIES

(4) ETR8-2

Adjustable U-Bracket for ceiling, wall or scaffold mounting of the 108P

(5) ETR112XT

Adjustable U-Bracket for ceiling, wall or scaffold mounting of the 112P

(6) ETR15P

Adjustable U-Bracket for ceiling, wall or scaffold mounting of the SB15P

(7) XT-LIFTBAR

Allows for single point rigging of 112P loudspeaker enclosures with 5 pick points available for tilt adjustment



ETR112XT



ETR8-2



ETR15P



XT-LIFTBAR

Figure 3: P Series Rigging Components

1.1 OVERVIEW

L-ACOUSTICS I08P and I12P self-powered coaxial loudspeakers are intended for distributed sound reinforcement in small- to medium-sized portable applications or for use with the SB15P self-powered subwoofer for 3-way applications such as small- to medium-sized FOH or stage monitoring (drum/side fill). All P-series enclosures feature highly-advanced loudspeaker components and rigging accessories while benefiting from the sonic accuracy and flexibility afforded by application-engineered digital presets.

I08P

The I08P is a 250 x 500 watt bi-amplified, digitally-processed loudspeaker featuring a 1" exit HF compression driver coaxially-loaded by an eight-inch low frequency transducer. Coaxial loading produces coherent point source radiation with 100-degree axisymmetric directivity along with superimposed LF/HF dispersion characteristics free of the polar lobing effects associated with traditional 2-way studio monitor configurations (i.e., separate woofer/tweeter). The end result is precise, stable image localization that is ideal for stereo or surround sound monitoring.

Integral digital crossover filtering, component time alignment and equalization provide superb sonic performance plus added flexibility due to the availability of four application-engineered presets (FILL, FRONT, MONITOR, X-OVER).

Accurate frequency response and imaging combined with elevated SPL output capacity make the I08P ideal for use as a high performance nearfield monitor for live FOH mix engineering and for stereo or 5.1 monitoring in studio, broadcast or post production environments. For nearfield monitoring applications, either FILL (free space conditions, for example, when the I08P is placed on a console bridge) or MONITOR (half space conditions, for example, when the I08P is wall- or soffit-mounted) presets should be selected.

Due to its' high power:size ratio, plug-and-play ease-of-use, versatile application-oriented presets and multi-purpose enclosure format, the I08P is also suitable for a wide variety of portable sound reinforcement applications. For proximity reinforcement such as distributed front fill, the I08P provides optimum fidelity and intelligibility, satisfying the strict requirements of classical music and opera. The compact, truncated wedge-shaped enclosure format provides a visually-discrete solution for floor monitoring, keyboard monitoring or underbalcony use and with the addition of L-ACOUSTICS subwoofers, the I08P is also suitable for small format FOH applications.

In addition to proximity fill and monitoring, the I08P can be used for portable distributed sound reinforcement in theatre, trade show, concert hall, houses of worship, congress centre, club, restaurant, retail, corporate boardroom or television applications. To facilitate installation, a pole mount socket is included as standard and an adjustable U-bracket is available as an optional rigging accessory for ceiling, wall, scaffold or truss mounting.



Figure 4: I08P Enclosure

112P

Ideal for multi-purpose, portable sound reinforcement, the 112P features advanced loudspeaker components powered by a 1000 W power amplifier module with dedicated on-board digital signal processing. Four application-engineered presets are available (FILL, FRONT, MONITOR, X-OVER), complementing the considerable flexibility of the 112P by providing convenient, plug-and-play ease of operation.

Featuring a 1.4" exit compression driver coaxially-loaded by a 12" transducer, the 112P provides coherent point source radiation with 90-degree axi-symmetric directivity (identical horizontal, vertical and axial coverage). Due to the coaxial component configuration, power response is free of the polar lobing effects typical of traditional horn / woofer combinations.

The net result is natural, studio monitor sound quality - ideal for proximity fill use or portable distributed sound reinforcement in theatre, congress centre, concert hall, trade show, corporate A/V, houses of worship, club, or television applications. When used with the L-ACOUSTICS SB15P self-powered subwoofer, the 112P is also highly suitable for side fill, drum monitoring or small-to-medium format front-of-house (FOH) applications.

Due to its compact, wedge-shaped enclosure format, the 112P provides an exceptionally high performance floor monitor solution. Excellent image and coverage stability is obtained due to the coaxial configuration and the performer experiences a generous, homogeneous coverage pattern without the subjective impression and potential feedback problems of listening to a separate horn / woofer combination.

To facilitate installation, pole mount sockets are included as standard and optional rigging accessories include an adjustable U-bracket for ceiling, wall, scaffold or truss mounting and a liftbar adapter that allows for single point rigging of the 112P (5 pick points available for tilt adjustment).



Figure 5: 112P Enclosure
7/12/2007

SB15P

The SB15P (Sub Bass 15" Powered) is the companion subwoofer for L-ACOUSTICS I08P and I12P self-powered coaxial loudspeakers. Featuring a front-loaded fifteen-inch transducer loaded in an optimum-sized/-tuned vented enclosure, the SB15P combines the convenience of self-powered performance with the power of digital signal processing.

The 15" component employed in the SB15P features elevated power handling and excursion capability along with reduced distortion and thermal power compression. Advanced component performance is complemented by integral power amplification and protection to provide exceptional SPL output and secure operation. Optimized tuning provides an ideal combination of temporal accuracy, bass articulation, musicality and low end definition that only a front-loaded subwoofer can provide.

The compact dimensions of the SB15P provide a high degree of flexibility for installations where space is at a premium. Typical applications include portable distributed sound reinforcement for theatre, congress centre, concert hall, trade show, corporate A/V, houses of worship, club, conference room, multimedia installations or television. The SB15P is also ideal for stage monitoring applications such as compact side fill, keyboard or drum fill monitoring. For studio or nearfield monitoring, the SB15P can be used with I08P enclosures in stereo, 5.1 or 7.1 configurations.

A built-in pole mount socket is provided as standard, facilitating the creation of a compact FOH system when the SB15P is used with I08P or I12P enclosures. An adjustable U bracket is available as an optional rigging accessory for ceiling, wall, scaffold or truss mounting, adding a unique degree of versatility for fixed installation.



Figure 6: SB15P Enclosure

1.2 108P, 112P SERIES PRESETS

Four application-engineered presets are selectable via rear panel push button switch:

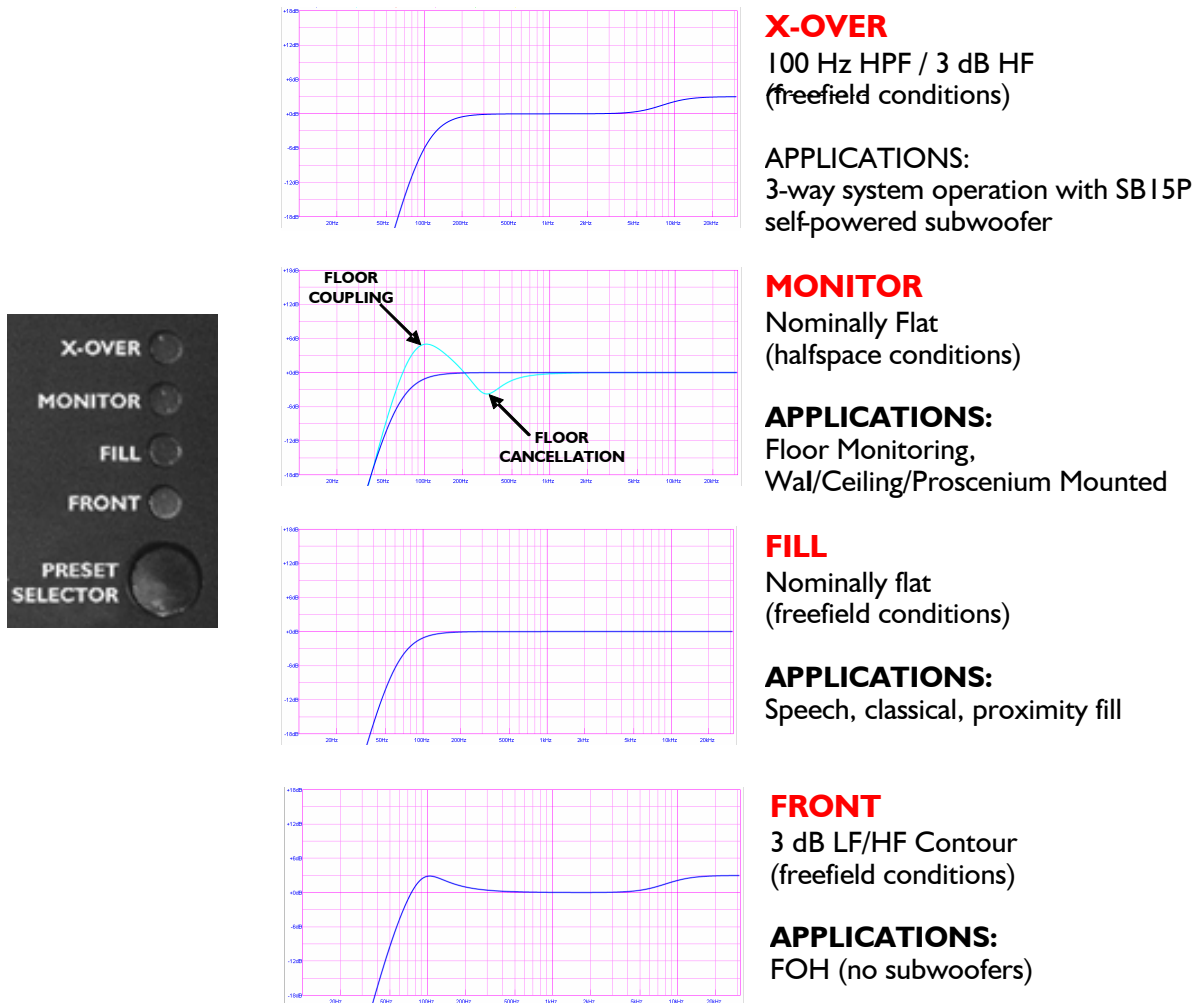

Figure 7: 108P, 112P preset selector switch closeup and preset options

Note: To memorize a preset (so that it is automatically recalled when cycling the mains power on/off), select the desired preset and hold the preset selector button until the led display is blinking.

FRONT presets are for standalone FOH operation (without subwoofers) where low and high frequency shelving equalization provide a frequency response contour suitable for music applications.

FILL presets provide nominally flat response for nearfield monitoring, speech reinforcement and classical music applications or, in general, when P Series enclosures are used as a close proximity fill enclosure.

FRONT and FILL presets are derived under freefield measurement conditions

MONITOR presets include additional low frequency equalization to account for half-space loading conditions and are intended for floor monitoring applications or installations where P Series loudspeakers are wall- or ceiling-mounted.

MONITOR presets are nominally flat under half-space measurement conditions

XOVER presets apply a 100 Hz highpass filter and a 3 dB high frequency shelving equalization contour for use of the 108P or 112P with the L-ACOUSTICS SB15P self-powered subwoofer.

1.3 SB15P PRESETS

The SB15P has an operating bandwidth of 45 – 100 Hz (-3 dB) with a usable low frequency of 40 Hz (-10 dB) and is optimized for use with 108P or 112P enclosures as a low frequency extension.

When used with 108P or 112P enclosures in X-OVER mode, the SB15P should be operated with positive polarity.

When used with 108P or 112P enclosures in FILL, FRONT or MONITOR mode, the SB15P should be operated with negative polarity.

Note: To memorize a preset (so that it is automatically recalled when cycling the mains power on/off), select the desired preset and hold the preset selector button until the led display is blinking.



Figure 8: SB15P preset selector switch closeup

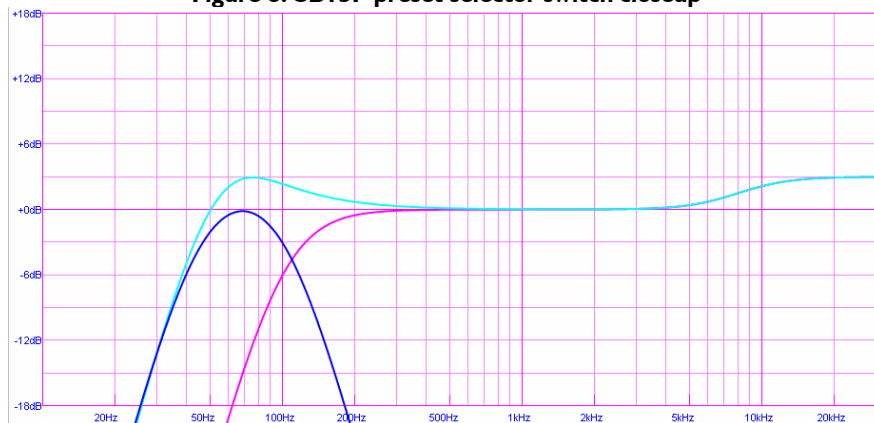

Figure 9: SB15P with positive polarity, 108P or 112P in X-OVER mode provides a 3 dB sub/low frequency contour (rear panel volume at 0 dB)

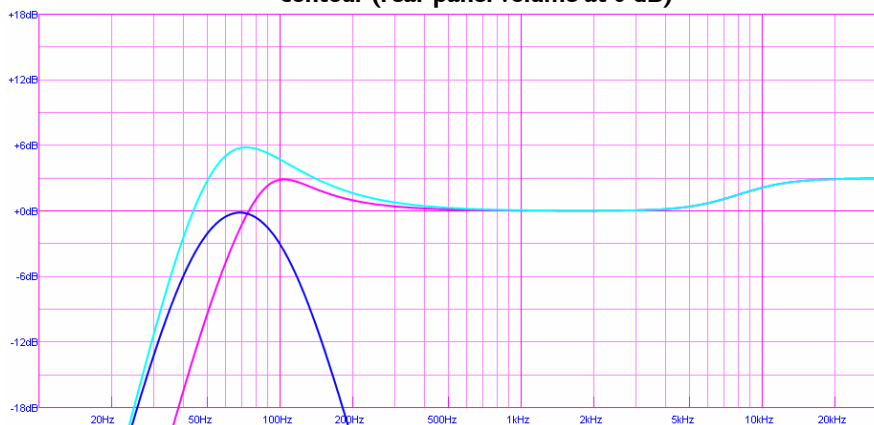

Figure 10: SB15P with negative polarity, 108P or 112P in FRONT mode provides a 6 dB sub/low frequency contour (rear panel volume at 0 dB). The SB15P should also be operated with negative polarity when FILL or MONITOR presets are selected for the 108P or 112P to obtain a similar sub/low frequency contour

1.4 I08P DESCRIPTION

The I08P is a self-powered, bi-amplified, two-way coaxial full range loudspeaker containing one direct radiating, bass reflex-loaded, weather-resistant 8-inch low frequency transducer and one 25 mm (1.0 inch) exit, 44 mm (1.7 inch) voice coil diameter, polyester diaphragm, compression driver. The cone body of the 8-inch low frequency component provides pattern control loading for the compression driver and yields a 100-degree conical directivity pattern that is axi-symmetric. As a full range system, frequency response is 65 Hz to 20 kHz with less than +/- 3 dB variation and the usable bandwidth is 50 Hz to 22 kHz (-10 dB).

The I08P contains internal digital signal processing electronics and a two-channel power amplifier. The power amplifier provides 500 W continuous (1 kHz, 0.5% THD) into 4 ohms and 250 W continuous (1 kHz, 0.5% THD) into 8 ohms for powering low and high frequency transducers, respectively. The power amplifier provides thermal protection, short-circuit/overload output protection, clip and RMS signal limiting. Digital processing electronics also provides corrective component and system equalization, component time alignment and crossover filtering.

Four presets are selectable via rear-panel push button switch with the following characteristics: FILL has nominally flat frequency response when the loudspeaker is used under freefield conditions; FRONT has +3 dB low and high frequency shelving characteristics under freefield conditions; MONITOR has nominally flat response under half-space loading conditions; X-OVER provides a 100 Hz high pass filter and +3 dB high frequency shelving characteristics for use of the I08P with the L-ACOUSTICS SB15P self-powered subwoofer. Connection to the I08P is made via two parallel XLR connectors and gain is controllable via rear panel volume potentiometer. AC power connectors are PowerCon type and 115V or 230V operation is selectable via rear panel rotary switch.

The I08P has a truncated wedge shape with a curved front profile. Dimensions are 42.1 cm (16.6 in) high, 25.0 cm (9.8 in) wide by 29.9 cm (11.8 in) deep. When used as a floor monitor, the front baffle of the enclosure is oriented at 30° with respect to vertical. Enclosure weight is 12.8 kg (28.2 lbs) and cabinet construction consists of 15 mm (0.6 in) and 18 mm (0.7 in) Baltic birch plywood with joints that are sealed, screwed and rabbeted. The finish is maroon gray, high resiliency paint and the front of the I08P is protected by a black powder-coated 1.5 mm (0.06 in) thick steel grill covered with acoustically-transparent grille cloth. The I08P has a 35 mm (1.38 in) diameter pole mount socket mounted on the bottom side and a recessed plate on the top side for rigging the enclosure in conjunction with an adjustable U-bracket assembly.



Figure 11: I08P (floor monitor orientation)

1.5 112P DESCRIPTION

The 112P is a self-powered, two-way, coaxial full range loudspeaker containing one direct radiating, bass reflex-loaded, weather-resistant 12-inch low frequency transducer and one 1.4 inch exit, 3 inch voice coil diameter, titanium alloy diaphragm compression driver. The cone body of the 12" low frequency component provides pattern control loading for the compression driver and yields a 90-degree conical directivity pattern that is axi-symmetrical. As a full range system, the frequency response is 60 Hz to 18 kHz with less than ± 3 dB variation and the usable bandwidth is 50 Hz to 20 kHz (-10 dB).

The 112P contains internal digital signal processing electronics and a mono bridged power amplifier that provides 1000 W continuous (1 kHz, 0.5% THD) into 8 ohms with thermal protection, short-circuit/overload output protection, clip and RMS signal limiting. Integral digital signal processing provides corrective component and system equalization. Four presets are selectable via rear-panel push button switch with the following characteristics: FILL has nominally flat frequency response when the loudspeaker is used under freefield conditions; FRONT has +3 dB low and high frequency shelving characteristics under freefield conditions; MONITOR has nominally flat response under half-space loading conditions; X-OVER provides a 100 Hz high pass filter and +3 dB high frequency shelving characteristics for use of the 112P with the L-ACOUSTICS SB15P self-powered subwoofer.

Connection to the 112P is made via two parallel XLR connectors and gain is controllable via rear panel volume potentiometer. AC power connectors are PowerCon type and 115V or 230V operation can be selected via rear panel rotary switch.

The 112P has a truncated wedge shape with a curved front profile. Dimensions are 54 cm (21.3 in) high, 41.6 cm (16.1 in) wide and 39 cm (15.4 in) deep. When used as a floor monitor, the front baffle of the 112P is oriented at a 30 degree angle with respect to vertical. Enclosure weight is 32.2 kg (70.9 lbs) and cabinet construction consists of 30 mm (1.18 in) and 18 mm (0.70 in) Baltic birch plywood with internal steel bracing and joints that are sealed, screwed and rabbeted. The finish is maroon-gray high resilient paint and the front of the enclosure is protected by a black powder-coated, 1.5 mm (0.06 in) thick steel grill covered with acoustically-transparent grille cloth.

The 112P has 36 mm (1.42 in) diameter pole mount sockets mounted on the top and bottom sides that can be used with a U-bracket accessory for rigging the enclosure in either horizontal or vertical orientations with angular adjustment at 10 degree resolution. The XTLIFTBAR accessory functions with either of the pole mount sockets and provides five attachment points for rigging purposes.



Figure 12: 112P (floor monitor orientation)

I.6 SB15P DESCRIPTION

The SB15P self-powered subwoofer contains a single 15-inch loudspeaker component that is front-loaded in an optimally-tuned and vented enclosure. Usable frequency response is 45 to 100 Hz with less than ± 3 dB variation and the usable -10 dB low frequency response is 40 Hz. Loudspeaker ports are of large area dimension in order to minimize port non-linearity and turbulence effects.

The fifteen-inch transducer has a 4-inch (100 mm) diameter edgewound copper ribbon voice coil, 18 mm (0.71 in) peak excursion capability, diecast aluminum frame, massive vented magnet structure and high thermal capacity that provides reduced power compression, long term reliability and low distortion output.

The SB15P features internal digital signal processing electronics and a mono bridged power amplifier that provides 1000 W continuous (1 kHz, 0.5% THD) into 8 ohms with thermal protection, short-circuit/overload output protection and clip / RMS signal limiting. Integral digital signal processing performs crossover filtering (100 Hz low pass filter) and system equalization for use of the SB15P in conjunction with the 108P or 112P. Positive or negative polarity operation is selectable via rear-panel push button switch.

When used with 108P or 112P enclosures in X-OVER mode, the SB15P should be operated with positive polarity.

When used with 108P or 112P enclosures in FILL, FRONT or MONITOR mode, the SB15P should be operated with negative polarity.

Connection to the SB15P is made via two parallel XLR connectors and gain is controllable via rear panel potentiometer. AC power connectors are PowerCon type and 115V or 230V operation is selectable via rear panel slider switch.

The enclosure is constructed of 18 mm (0.7 in) baltic birch and is internally braced with steel corner plates and sealed, screwed, rabbeted joints in order to remain vibration-free at extreme sound pressure levels. Dimensions are 445 mm (17.5 in) high, 520 mm (20.5 in) wide and 520 mm (20.5 in) deep and the enclosure weight is 36 kg (79.4 lbs). Finish is maroon-gray high resilient paint and the front of the enclosure is protected by a black powder-coated, 1.5 mm (0.06 in) thick steel grill, covered with acoustically-transparent grille cloth.

Two recessed handles are located on the sides of the SB15P for handling purposes and a 36-mm (1.42 in) diameter pole mount socket mounted on the top side. When used in conjunction with a bottom attachment plate, the pole mount socket can be used with the optional ETR15P U-bracket accessory for rigging the enclosure in either horizontal or vertical orientations with continuous angular adjustment.

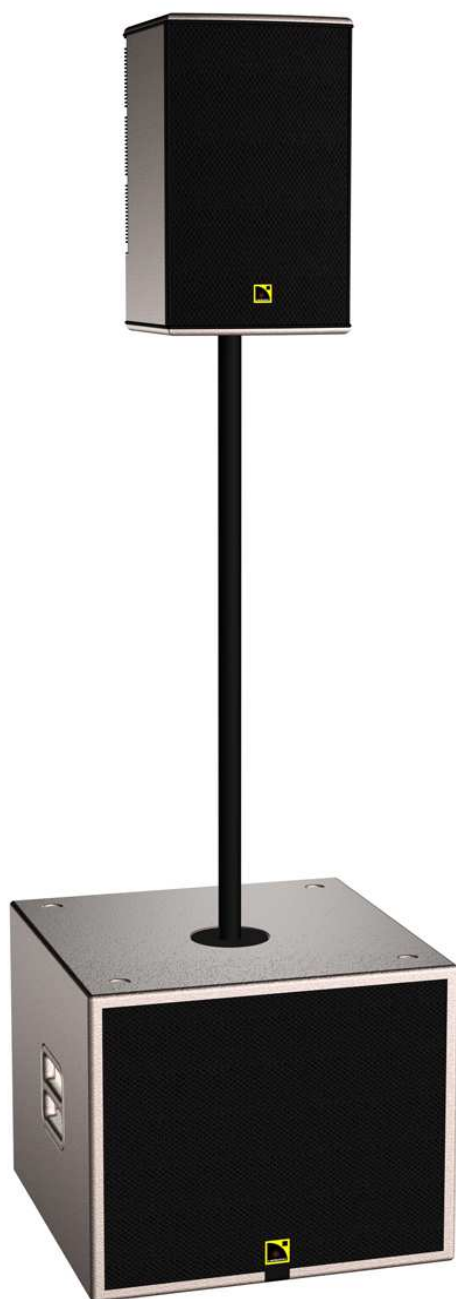

Figure 13: SB15P (with pole-mounted I08P)

2. CONNECTORS AND CABLES

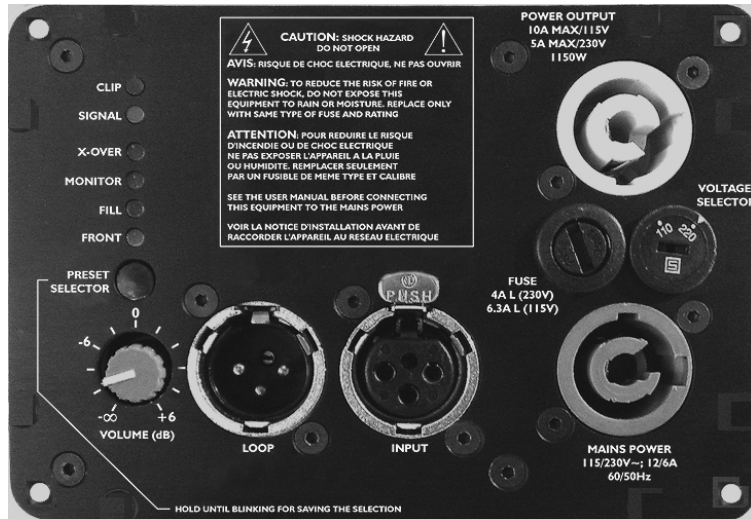

Figure 14a: I08P / I12P DSP Power Amplifier Module Rear Panel

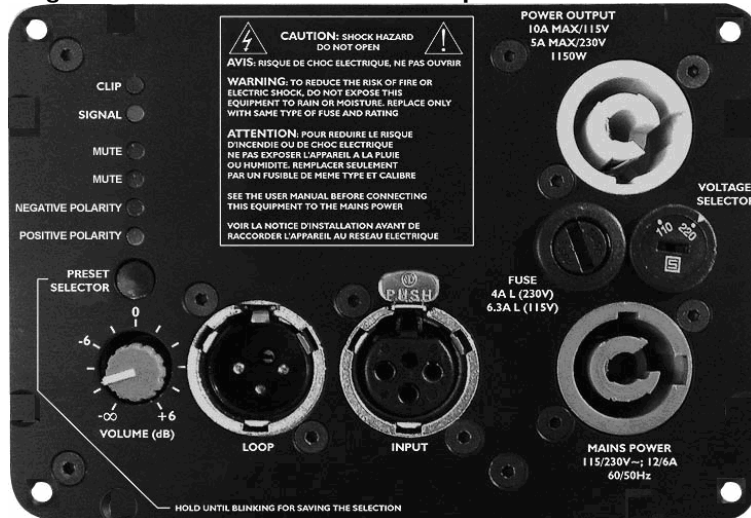

Figure 14b: SB15P DSP Power Amplifier Module Rear Panel

⚠ Before applying AC power, ensure that the voltage selector is correctly set for the mains power source (115 V or 230 V) and that the fuse has the appropriate rating.

⚠ Always use the mains power cable that was provided with your I08P, I12P or SB15P.

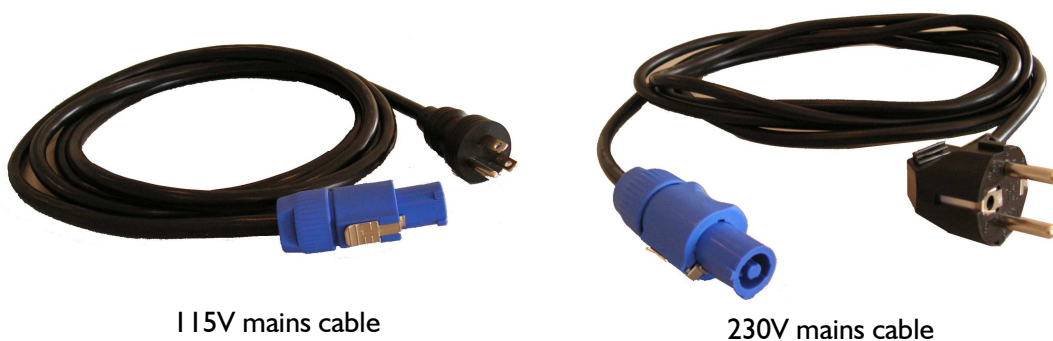

Figure 15: P Series mains power cables

⚠ Do not connect I08P, I12P or SB15P loudspeakers to an unearthed mains supply or by using an unearthed mains cable.

To daisy-chain connect mains power from a 108, 112P or SB15P loudspeaker to additional P Series enclosures (up to 3), use a cable with a grey Neutrik PowerCon NAC3FCB connector at one end (connected to the Power Output connector of the P Series enclosure that is supplying power) and a blue Neutrik PowerCon NAC3FCA connector at the other end (connected to the Power Input connector of the P Series enclosure that is being daisy-chain connected).

Note: Neutrik PowerCon connectors are color-coded:

Blue = power input = Neutrik NAC3FCA PowerCon connector

Grey = power output = Neutrik NAC3FCB PowerCon connector

⚠ Never daisy chain connect more than 3 P series enclosures using the Power Output connector.

⚠ Do not daisy-chain connect P Series enclosures using an unearthed PowerCon NAC3FCA to PowerCon NAC3FCAB cable.

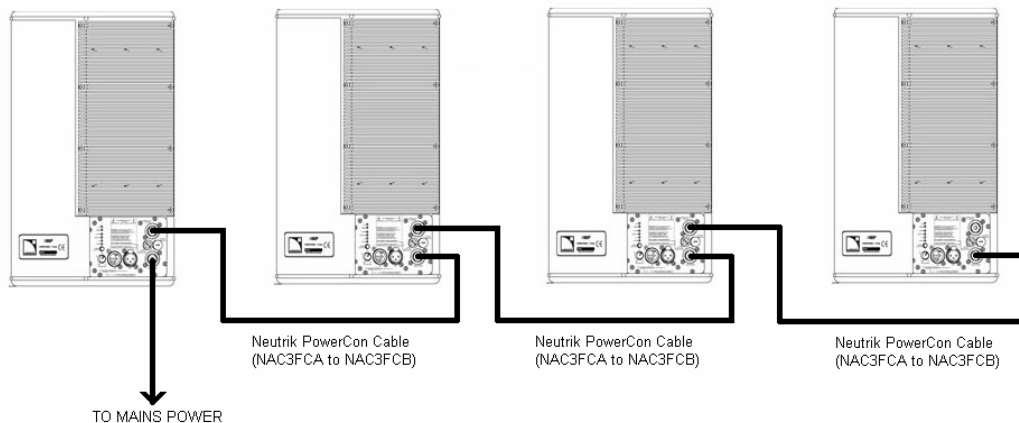

Figure 16: Daisy-chain connection of P Series enclosures

These cables (NAC3FCA to NAC3FCB) must handle at least 5A@230V or 10A@115V.

SIGNAL INPUT/LOOP THROUGH

P Series loudspeakers are supplied with dual XLR connectors that are internally wired in parallel, allowing for loop through connection and parallel operation of multiple 108P, 112P or SB15P enclosures.

XLR connectors are wired as follows:

- Pin 1 = ground
- Pin 2 = signal +ve
- Pin 3 = signal -ve

Unbalanced sources (for example, RCA or 1/4" TS phone jack connectors) can be connected to the 108P or 112P provided that pin 3 is grounded to pin 1 (see Figure 17).

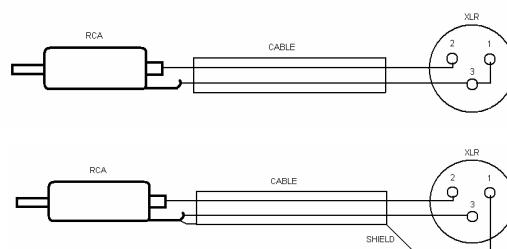

Figure 17: Connecting unbalanced sources

Note: When cabling your P Series loudspeaker for the first time, set the volume control fully counter-clockwise ($-\infty$). The input sensitivity of the 108P, 112P or SB15P can be matched to the output of the mixing console (or other program source) by using the volume control on the rear panel.

The ferrite provided with your P series loudspeaker helps improve immunity to electromagnetic fields (above 100 MHz) and should be placed on the XLR audio cable used for connecting input signal to the 108P, 112P or SB15P. Perform a cable loop near the male XLR plug when attaching the ferrite.

3. APPLICATIONS

P Series loudspeakers are intended for portable distributed sound reinforcement, nearfield monitoring (108P), floor monitoring or small- to medium-scale Front-Of-House (FOH) applications. Guidelines for the use of P Series loudspeakers in these applications are discussed in this section.

3.1 AIMING P SERIES ENCLOSURES

Due to their controlled directivity behavior, P Series enclosures should be aimed so as to geometrically cover the desired audience area with the main zero degree axis oriented towards the middle or rear of the audience area. Since the wavefront radiated by an axi-symmetric sound source has directivity that is smoothly increasing with frequency, this helps to match coverage, frequency response and SPL to the acoustic environment of a typical auditorium (i.e., normally the reverberation time in auditoria decreases smoothly above 1 kHz and at greater distances in the venue, the low frequency energy is fairly constant due to the reverberant field).

Loudspeaker focus or aiming should be adjusted so that maximum HF energy is directed towards the farthest listening areas – this helps to balance the SPL attenuation with distance that occurs in the direct field. At closer listening positions, the off-axis attenuation at higher frequencies provides a similar tonal balance and the overall SPL attenuation with distance is reduced.

Although P Series enclosures have controlled directivity attenuation properties it is important not to have the first members of the audience too close to the system (i.e., in order not to produce excessive sound pressure levels down front). Ideally, the ratio between the shortest and the furthest distance covered should not exceed 1:4 and in order to obtain this throw distance ratio, it is often desirable to fly the system. However, when P Series enclosures are flown and the audience seating area begins very close to the stage, it is often necessary to use distributed front-fill speakers (for example, 108P) or a stacked left/right 112P stereo infill system in order to improve coverage and image localization for the first few rows of the audience.

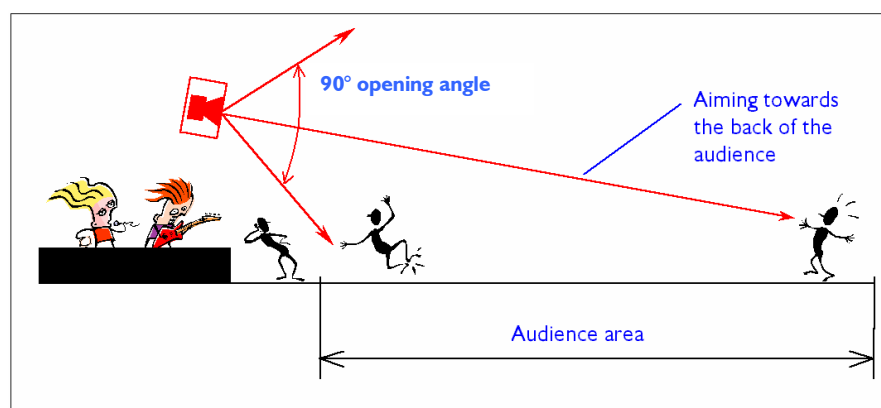

Figure 18: General guidelines for aiming P Series enclosures

3.2 DISTRIBUTED SOUND REINFORCEMENT

Distributed sound reinforcement using P Series enclosures can provide even SPL coverage and frequency response while reducing audible interference effects. For distributed installation, the optimum spacing between enclosures will depend on the coverage angle of the individual enclosure (100 degrees for I08P, 90 degrees for I12P) and the throw distance to the audience listening plane.

In general, the goal is to separate P Series enclosures so that the -6 dB coverage angle of one enclosure is aligned with the main 0 degree axis of the other enclosure (and vice versa) at the listening plane of the audience. This is termed centre-to-centre alignment and is illustrated in Figure 15.

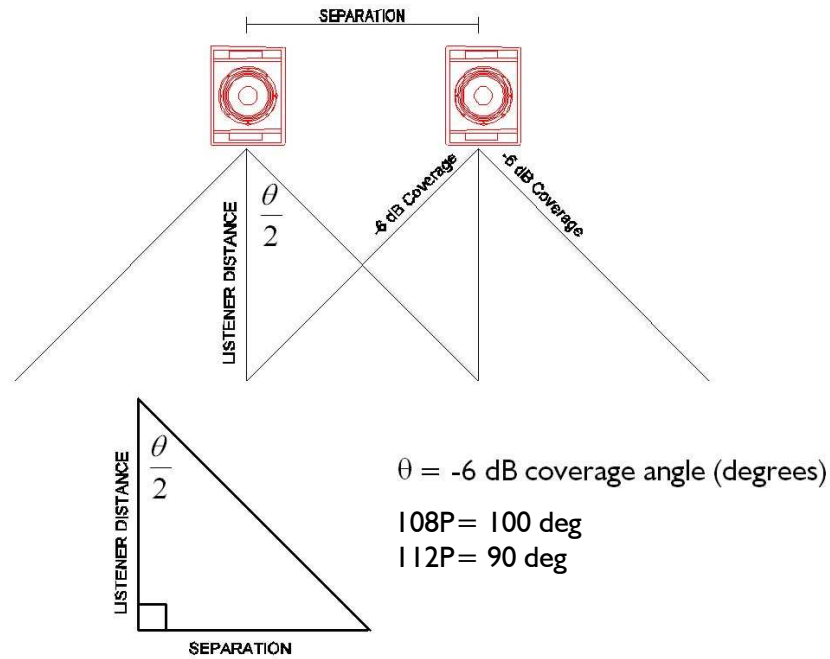

Figure 19: General guidelines for I08P or I12P enclosure spacing for distributed sound reinforcement

3.3 I08P NEARFIELD MONITORING

Accurate frequency response (due to on-board DSP) and imaging (due to the point source coaxial configuration) combined with elevated SPL output capacity make the I08P ideal for use as a high performance nearfield monitor for live FOH mix engineering and for stereo or 5.1 monitoring in studio, broadcast or post production environments.

For nearfield monitoring, either FILL (free space conditions, for example, when the I08P is placed on a console bridge) or MONITOR (half space conditions, for example, when the I08P is wall- or soffit-mounted) presets should be selected.

For stereo monitoring, left/right I08P separation should be approximately equal to the throw distance to the listening position. Horizontal azimuth (panning) should be adjusted so that the zero degree axes of left/right I08P monitors are oriented towards the listening position.

3.4 FLOOR MONITORING

For floor monitoring, the coaxial component configuration employed in the I12P provides a high degree of image and coverage stability. The benefits of axi-symmetric directivity are readily apparent since the performer is in close physical proximity to the enclosure and experiences a generous, homogeneous coverage pattern without the subjective impression (and potential feedback problems) of listening to a separate horn / woofer combination.

The MONITOR preset accounts for half-space loading conditions, i.e., there is a 6 dB increase around 100 Hz (due to floor coupling), followed by a broad cancellation that occurs between 200 – 600 Hz (due to floor reflections). The MONITOR preset compensates for these two half-space loading effects and provides a nominally flat frequency response curve with excellent fidelity and feedback resistance.

When using I12P enclosures in pairs for floor monitoring, the same principles apply as for distributed systems, i.e., the optimum spacing between floor monitors depends on the coverage angle of the enclosure (90 degrees for I12P) and the throw distance to the performing artist (which is determined by the 30-degree floor monitor angle with respect to vertical and the artist's height). Center-to-center overlap will provide the most uniform coverage (see Figure 19) and it is not advised to angle wedges in but to use them with the front faces parallel to each other (essentially, angling in wedges no longer provides optimum center-to-center overlap).

4. INSTALLATION PROCEDURES

The ETR8-2 is an optional accessory U-Bracket for wall or ceiling mounting of the I08P. Note: Always orient the ETR8-2 with the fixed arm on the bottom when installing the I08P in the vertical orientation

4.1 ETR8-2 U-BRACKET ATTACHMENT



(1) I08P and ETR8-2 U-bracket



(2) Remove locking pin on the pivoting arm



(3) U-bracket stud mates with I08P pole mount socket



(4) Remove recessed set screw on adapter plate (if necessary), rotate pivoting arm into position



(5) Attach pivoting arm using the tilt adjustment knob



(6) Secure the locking pin on the pivoting arm



(7) Rotate the U bracket to the desired position and securely tighten the tilt adjustment knob.



(7) Three attachment points are available on ETR8-2 for mounting the I08P in the horizontal orientation

Figure 20: ETR8-2 U-bracket installation procedure

4.2 ETRI 12XT U-BRACKET ATTACHMENT

The ETRI 12XT is an optional U-Bracket accessory for wall (vertical orientation) and ceiling or scaffold (horizontal orientation) mounting of the I12P. Three mount holes are available on the center section of the ETRI 12XT for bracket mounting. Pole mount adapter plates on the I12P in conjunction with angle selection locking pins on the ETRI 12XT allow for 10 degree angular resolution.

Note: When using ETRI 12XT in the vertical orientation, always install with the fixed arm on the bottom and the pivoting arm on top.



(1) ETRI 12XT U-bracket



(2) Closeup of angle selection locking pin

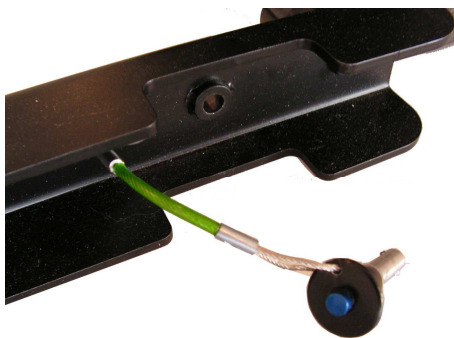

(3) Remove locking pins on both U-bracket arms



(4) Release pivoting arm locking pin

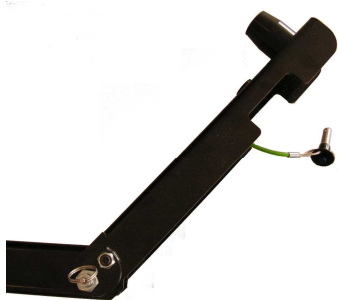

(5) ETRI 12XT - ready for attachment

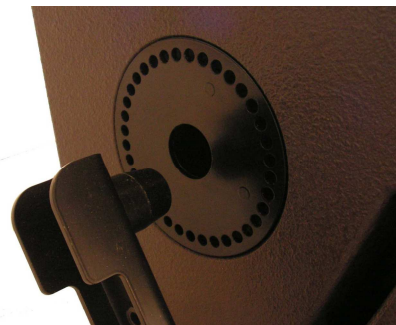

(6) I12P pole mount sockets mate with U-bracket studs (mount fixed arm first)



(7) Rotate the pivoting arm into position – the pivoting arm locking pin automatically secures the U-bracket



(8) Rotate the loudspeaker into position and select the desired angle. Secure using the locking pins on both fixed and pivoting arms



(9) Front perspective view



(9) Rear perspective view

Figure 21: ETRI I12XT U-bracket installation procedure

4.3 XTLIFTBAR ATTACHMENT

The optional XTLIFTBAR accessory allows for single point rigging of I12P enclosures with 5 pick points available for tilt adjustment. Pick point holes (from front to back) provide tilt angles of +18, +11, +3, -5 or -13 degrees, respectively.

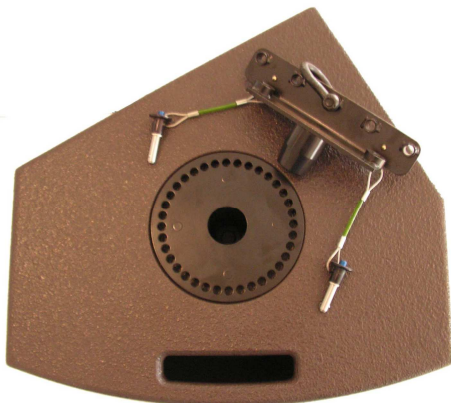

(1) XTLIFTBAR and the I12P enclosure

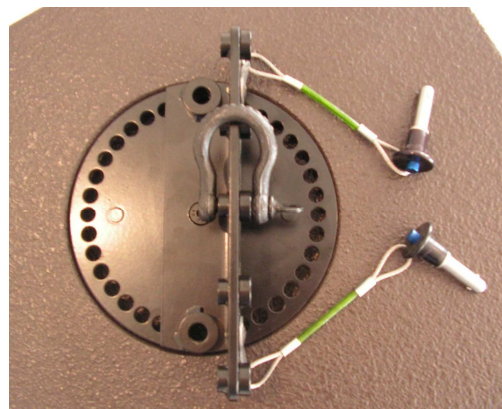

(2) The XTLIFTBAR mounting stud mates with I12P pole mount sockets (top or bottom)



(3) When installing XTLIFTBAR, ensure that the main section is aligned with the center of the enclosure in order to properly balance the center of gravity.



(4) Two locking pins are used to secure the XTLIFTBAR. Shackle locations (front to back) provide +18, +11, +3, -5, -13 degree tilt angles, respectively

Figure 22: XTLIFTBAR installation procedure

4.4 ETRI5P U-BRACKET ATTACHMENT

The ETRI5P is an optional U-Bracket accessory for wall mounting (vertical orientation only – fixed arm on the bottom / pivoting arm on top) and ceiling or scaffold mounting (horizontal orientation only). Three mount holes are available on the center section of the ETRI5P for bracket mounting and an M8 threaded insert (8 mm diameter) provided on the rear of the SBI5P for safety attachment.

Note: When using ETRI5P in the vertical orientation, always install with the fixed arm on the bottom and the pivoting arm on top.



(1) ETRI5P U-bracket



(2) Release pivoting arm locking pin



(3) ETRI5P - ready for attachment



(4) SBI5P pole mount socket mates with U-bracket stud



(5) Mount fixed arm first



(6) Rotate the pivoting arm into position



(7) Rotate the SBI5P to the desired angle and secure using the tilt adjustment knob (pivoting arm locking pin automatically secures the U-bracket as the adjustment knob is tightened)



(8) The recessed M8 insert (8 mm diameter) is available for attachment of an I-Bolt plus safety steel

Figure 23: ETRI5P U-bracket installation procedure

4.5 SAFETY RULES

L-ACOUSTICS loudspeakers can be ceiling-suspended or attached to a wall (vertical orientation only) using accessories that are either supplied or recommended by L-ACOUSTICS only. Installation must be done according to the following instructions :

Loudspeaker Model	Accessory model	Instructions	
		Wood support	Incompressible plain support (concrete or equivalent)
I08P	ETR8-2	Use 3 x self tapping screws with minimum 8 mm diameter and 60 mm length (hexagonal head screw DIN571 or equivalent)	Use 3 x anchors for heavy load 8 mm diameter and 50 mm length minimum
I12P	ETRI12XT	Use 3 x self tapping screws with minimum 8 mm diameter and 80 mm length (hexagonal head screw DIN571 or equivalent)	Use 3 x anchors for heavy load (10 mm diameter and 50 mm length minimum)
I12P	XTLIFTBAR	Do not suspend the loudspeaker from this type of support	Use a tested rigging point (130 kg) and in conformity with national safety regulations of the country of installation
SBI5P	ETRI5P	Use 3 x self tapping screws with minimum 8 mm diameter and 80 mm length (hexagonal head screw DIN571 or equivalent) Attach M8 (8 mm diameter) I-bolt to rear threaded insert for attachment of safety steel	Use 3 x anchors for heavy load (10 mm diameter and 50 mm length minimum) Attach M8 (8 mm diameter) I-bolt to rear threaded insert for attachment of safety steel

The I08P or I12P can be used with a loudspeaker stand (L-ACOUSTICS recommends the K&M 21435 or equivalent). The footprint (base diameter) must be at least 1300 mm and withstand a maximum centric load of 350 N (35 kg) or higher. Tripod stand legs must be completely opened and the height must not exceed 2020 mm when used with the I08P and 1420 mm when used with the I12P.

Always ensure that the ETRI12XT or ETRI5P rotating arm is securely fastened by verifying that the spring-loaded locking pin at the pivot point is correctly seated before adjusting the tilt angle of the I12P or SBI5P.

When using ETR8-2, ETRI12XT or ETRI5P in the vertical orientation, always install the U-bracket with the fixed arm on the bottom and the pivoting arm on top.

Maximum one I12P can be rigged per XTLIFTBAR.

L-ACOUSTICS recommends the use of safety steels at all times.

Attachment to concrete has not been investigated during the CSA approval.

5. P SERIES LOUDSPEAKER OPERATION



Before applying AC power, ensure that the voltage selector is correctly set for the mains power source (115 V or 230 V) and that the fuse has the appropriate rating.

Set the rear panel volume potentiometer to the minimum setting, i.e., fully counter-clockwise ($-\infty$)

Connect a program signal source (output from a mixing console, for example) to the XLR input of the I08P or I12P. For unbalanced sources, refer to Figure 17.

Note: The LOOP connector (male XLR) can be used to daisy-chain up to six P Series enclosures.

Ensure that the program signal source (mixing console output) is muted before powering your P series loudspeaker.

Power up the I08P, I12P or SB15P by connecting the PowerCon cable that was provided with your P series loudspeaker to an appropriate mains power source.

Note: The Power Output connector (grey PowerCon receptacle on the rear panel of the P Series enclosure) can be used to daisy-chain connect up to 3 additional P Series enclosures.

Note: Neutrik PowerCon connectors are color-coded:

BLUE = power input = Neutrik NAC3FCA PowerCon connector

GREY = power output = Neutrik NAC3FCB PowerCon connector

Select the desired preset for the I08P / I12P (FILL, FRONT, MONITOR or XOVER) and/or the SB15P (POSITIVE or NEGATIVE polarity) using the rear panel "Preset Selector" switch (see Section 1.2 and 1.3 for further details concerning P Series presets).

When used with I08P or I12P enclosures in X-OVER mode, the SB15P should be operated with positive polarity.

When used with I08P or I12P enclosures in FILL, FRONT or MONITOR mode, the SB15P should be operated with negative polarity.

Note: To memorize a preset (so that it is automatically recalled after cycling the mains power on/off), select the desired preset and hold the preset selector button until the led display is blinking.

Run program signal (e.g. CD player), and slowly bring up the mixing console output level to check that gain structure is correct.

If necessary, adjust the rear panel volume potentiometer in order to obtain the desired system gain structure.

Note: Signal LED illuminates when the input signal level is greater than -40 dBV.

Note: Clip LED illuminates when the amplifier output clip point is reached.

6. SPECIFICATIONS

6.1 108P SPECIFICATIONS

ACOUSTICAL PERFORMANCE

Frequency Response

Frequency response:	65 – 20k Hz (\pm 3 dB)	(FILL preset)
Usable bandwidth:	55 – 22k Hz (-10 dB)	

System Sensitivity

-21 dBu (0.071 Vrms)	94 dB SPL	65 – 20k Hz	(FILL preset)
----------------------	-----------	-------------	---------------

Nominal Directivity (-6 dB)

Axi-symmetrical	100° (\pm 15°)
-----------------	-------------------

System Output

	SPL		
One enclosure	115dB (cont)	125 dB (peak)	FILL preset
	113 dB (cont)	123 dB (peak)	XOVER preset

FILL preset provides nominally flat response under freefield conditions

XOVER preset applies a 100 Hz high pass filter and a 3 dB high frequency shelving eq contour

Components

LF 1 x 8" weather resistant loudspeaker (2" voice coil)

HF 1 x 1" exit compression driver (polyester diaphragm, coaxial assembly)

ELECTRICAL PERFORMANCE

Input

Type	Electronically balanced (pin 2 hot)
Max Input Level	+12 dBu (gain potentiometer at 0 dB position)

DSP

Sampling	24 bit / 48 kHz
Dynamic Range	> 105 dBA

Amplifier

Output Power	1 x 500 W (4 ohms – LF section) 1 x 250 W (8 ohms – HF section)
Gain	32 dB

Enclosure

Height	421 mm	16.6 in
Width	250 mm	9.8 in
Depth	299 mm	11.8 in
Floor Monitor Angle	30 degrees with respect to vertical	
Net Weight	12.8 kg	28.2 lbs
Shipping Weight	14.3 kg	31.5 lbs
Shipping Dimensions	490 x 330 x 370 mm 19.3 x 13.0 x 14.6 in	
Connectors	2 x XLR, 2 x PowerCon (input, loop through)	
Material	15 mm, 18 mm Baltic birch plywood	
Finish	Maroon-gray™	
Grill	Black epoxy perforated steel with acoustically-transparent, technically-advanced grille cloth	
Rigging	Integrated pole mount socket, adjustable U-bracket accessory available	

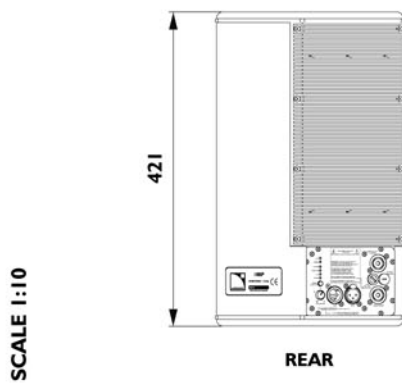
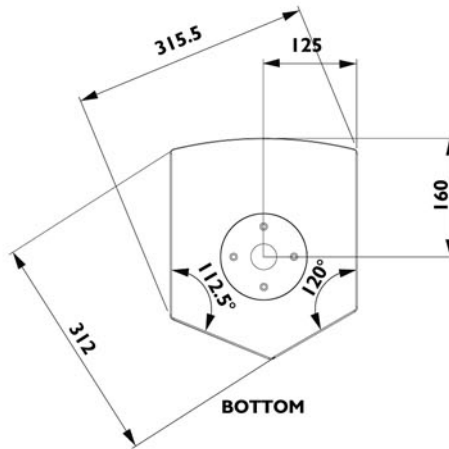
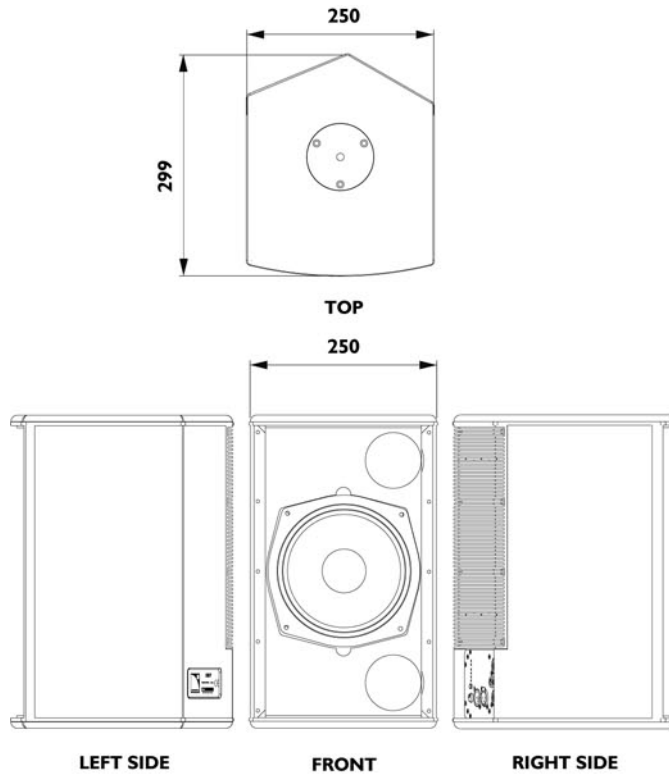

SCALE 1:10

(Dimensions in mm)

Figure 24: I08P Line Drawing

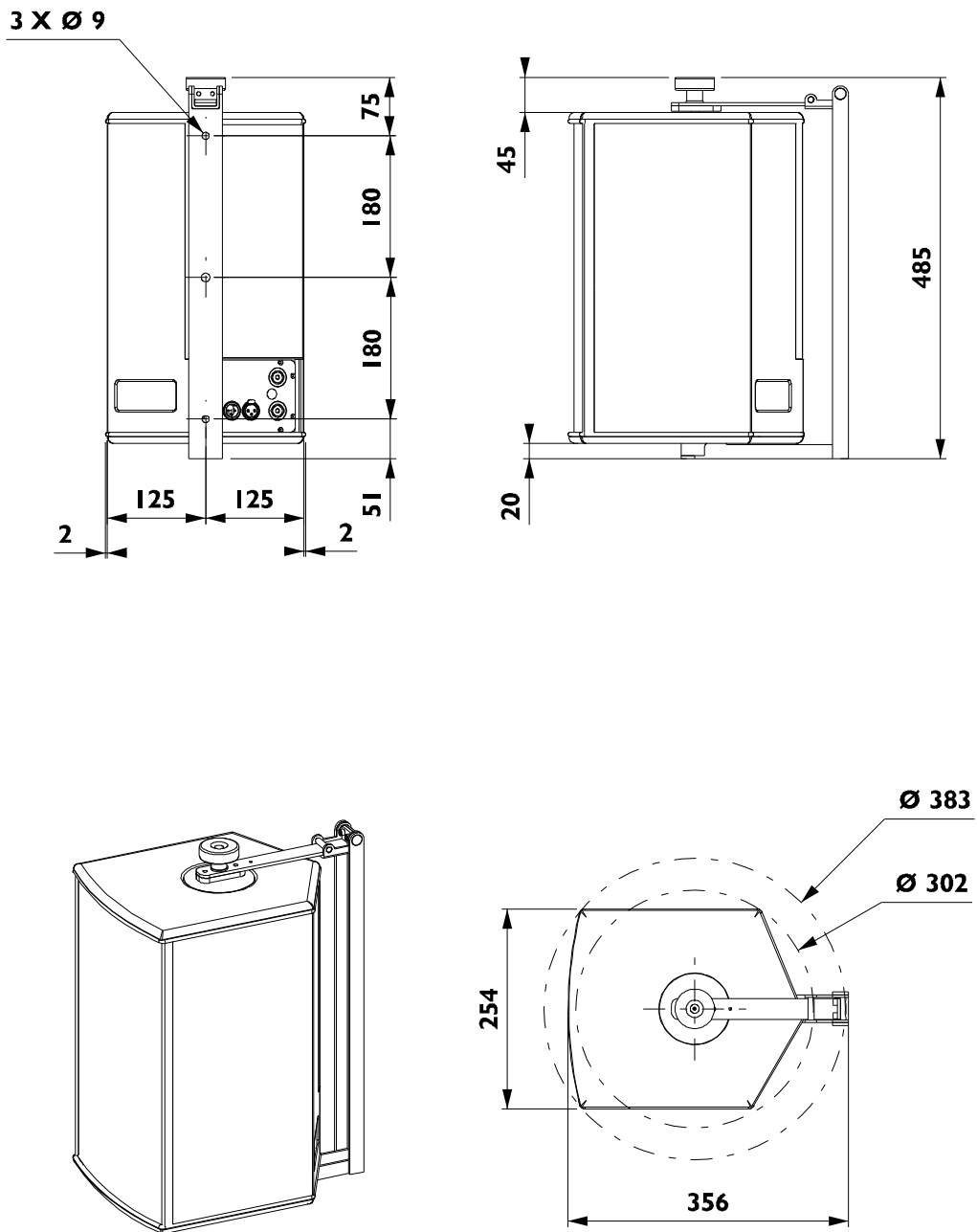

Figure 25: I08P + ETR8-2 Line Drawing

6.2 112P SPECIFICATIONS

ACOUSTICAL PERFORMANCE

Frequency Response

Frequency response:	60 – 18k Hz (± 3 dB)	(FILL preset)
Usable bandwidth:	50 – 20k Hz (-10 dB)	

System Sensitivity

-21 dBu (0.071 Vrms)	96 dB SPL	60 – 18k Hz	(FILL preset)
----------------------	-----------	-------------	---------------

Nominal Directivity (-6 dB)

Axi-symmetrical	90° ($\pm 20^\circ$)
-----------------	------------------------

System Output

	SPL		
One enclosure	121 dB (cont)	131 dB (peak)	FILL preset
	119 dB (cont)	129 dB (peak)	XOVER preset

FILL preset provides nominally flat response under freefield conditions

XOVER preset applies a 100 Hz high pass filter and a 3 dB high frequency shelving eq contour

Components

LF 1 x 12" weather resistant loudspeaker (3" voice coil)

HF 1 x 1.4" exit compression driver (titanium diaphragm, 3" voice coil, coaxial assembly)

ELECTRICAL PERFORMANCE

Input

Type	Electronically balanced (pin 2 hot)
Max Input Level	+12 dBu (gain potentiometer at 0 dB position)

DSP

Sampling	24 bit / 48 kHz
Dynamic Range	> 105 dBA

Amplifier

Output Power	1 x 1000 W (8 ohms)
Gain	32 dB

Enclosure

Height	540 mm	21.3 in
Width	416 mm	16.4 in
Depth	390 mm	15.4 in
Floor Monitor Angle	30 degrees with respect to vertical	
Net Weight	32.2 kg	70.9 lbs
Shipping Weight	35.5 kg	78.2 lbs
Shipping Dimensions	615 x 470 x 465 mm	
	24.2 x 18.5 x 18.3 in	
Connectors	2 x XLR, 2 x Power Con (input, loop through)	
Material	18 mm, 30 mm Baltic birch plywood	
Finish	Maroon-gray™	
Grill	Black epoxy perforated steel with acoustically-transparent, technically-advanced grille cloth	
Rigging	Integrated pole mount socket, adjustable U-bracket and liftbar accessories available	

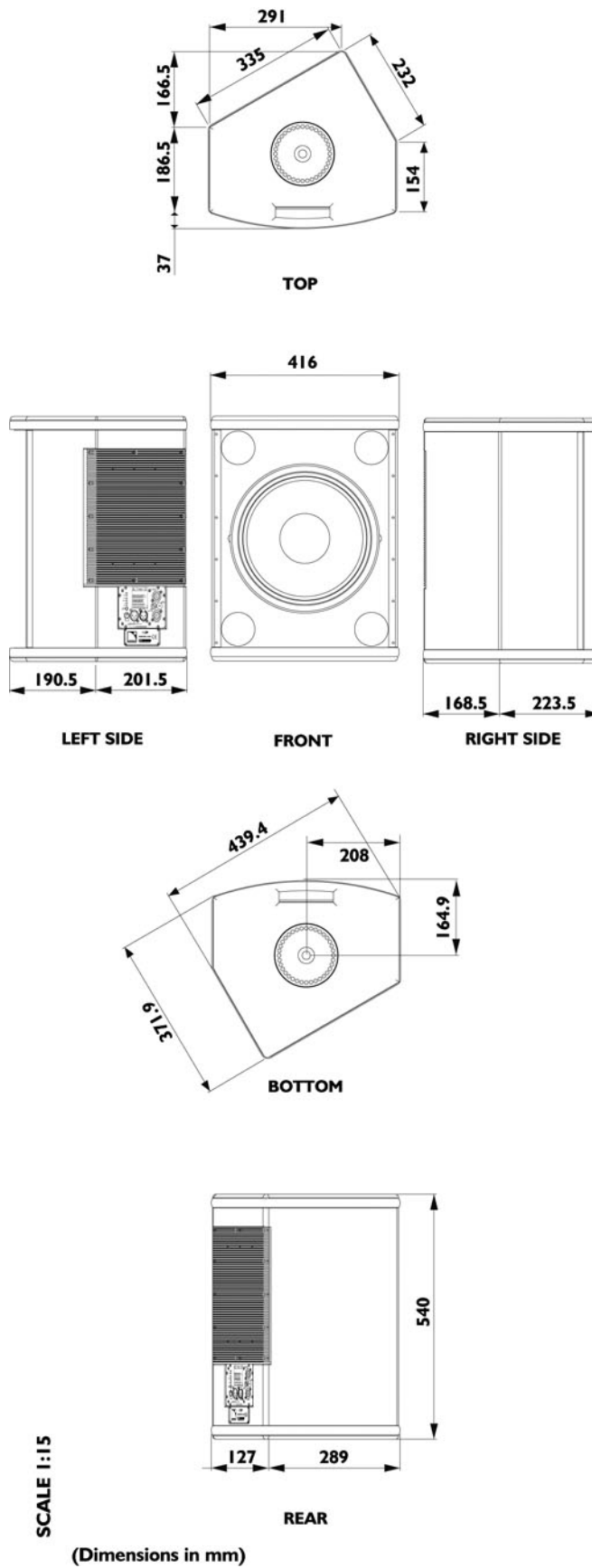

Figure 26: I12P Line Drawing

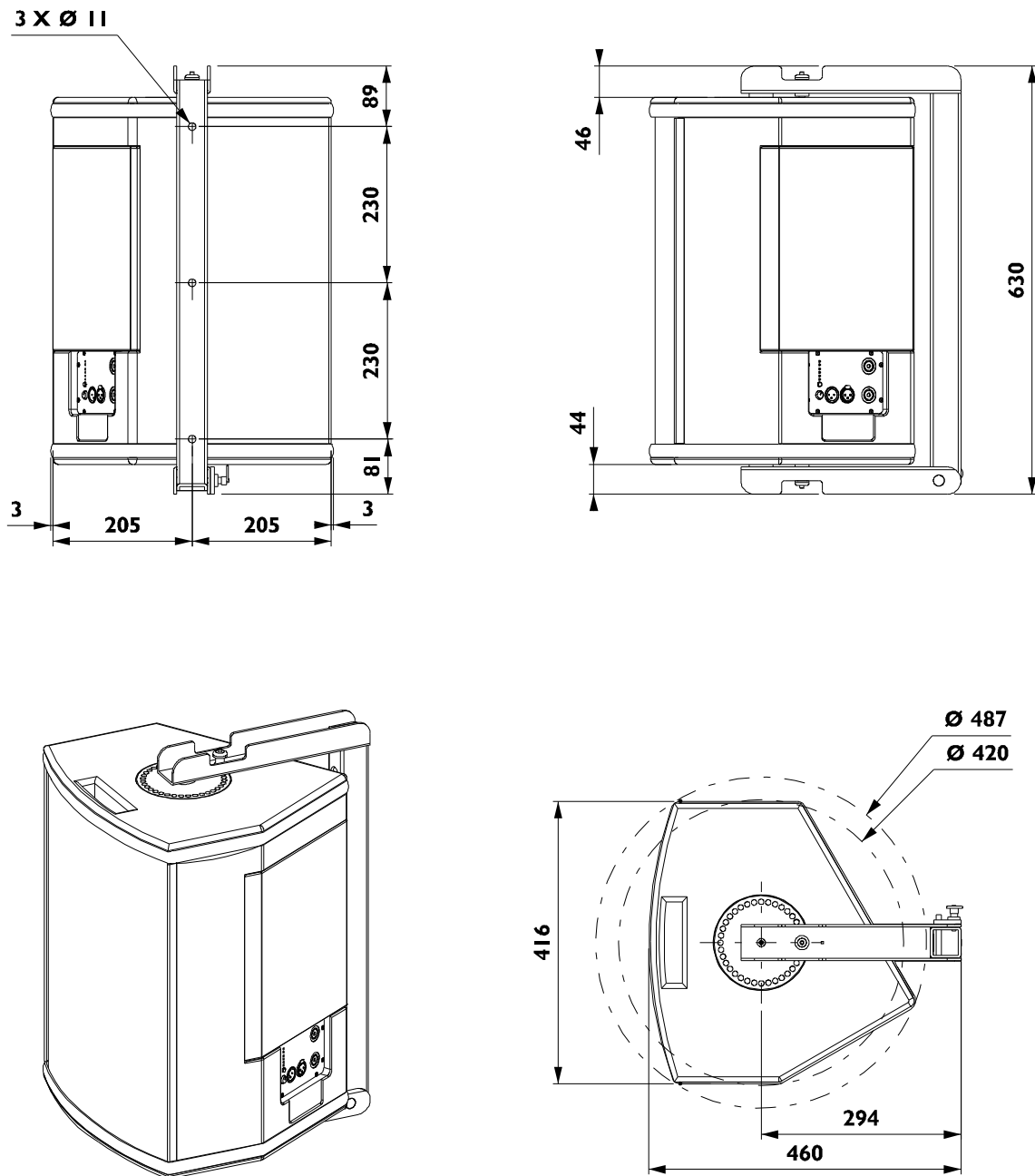

Figure 27: I12P + ETRI12XT Line Drawing

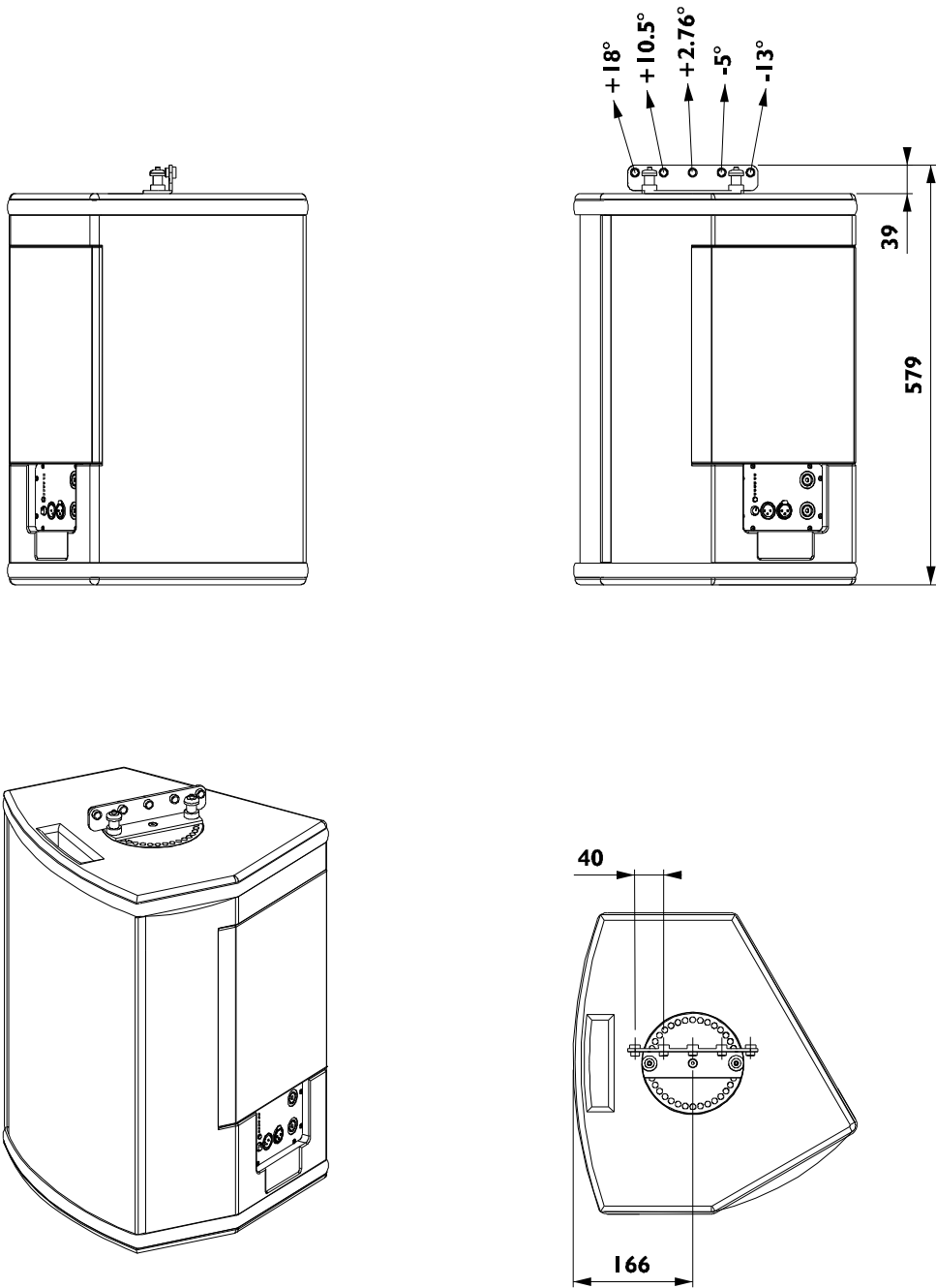

Figure 28: I12P + XTLIFTBAR Line Drawing

6.3 SB15P SPECIFICATIONS

ACOUSTICAL PERFORMANCE

Frequency Response

Operating Bandwidth:	45 – 100 Hz (± 3 dB)
Usable Low Frequency:	40 Hz (-10 dB)

System Sensitivity

-21 dBu (0.071 V _{rms})	93 dB SPL	45 – 200 Hz
-----------------------------------	-----------	-------------

System Output

	SPL	
One enclosure	121 dB (continuous)	131 dB (peak)
Two enclosures	127 dB (continuous)	137 dB (peak)
Three enclosures	133 dB (continuous)	143 dB (peak)

Components

1 x 15" weather resistant loudspeaker (4" voice coil)

ELECTRICAL PERFORMANCE

Input

Type	Electronically balanced (pin 2 hot)
Max Input Level	+12 dBu (gain potentiometer at 0 dB position)

DSP

Sampling	24 bit / 48 kHz
Dynamic Range	> 105 dBA

Amplifier

Output Power	1 x 1000 W (8 ohms)
Gain	32 dB

Enclosure

Height	445 mm	17.5 in
Width	520 mm	20.5 in
Depth	520 mm	20.5 in

Net Weight	36 kg	79.4 lbs
Shipping Weight	38 kg	83.3 lbs

Shipping Dimensions	650 x 530 x 610 mm
	25.6 x 20.9 x 24 in

Connectors	2 x XLR, 2 x Power Con (input, loop through)
------------	--

Material	18 mm, 24 mm Baltic birch plywood
Finish	Maroon-gray™

Grill	Black epoxy perforated steel with acoustically-transparent, technically-advanced grille cloth
-------	---

Rigging	Integrated pole mount socket, adjustable U-bracket accessory available
---------	---

Safety	Insert for attachment of an I-Bolt
--------	------------------------------------

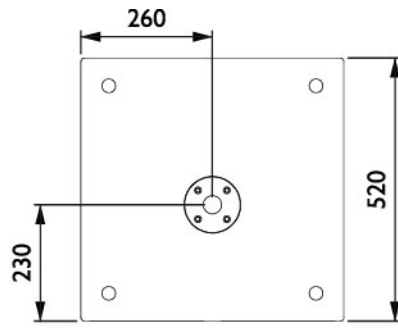

TOP

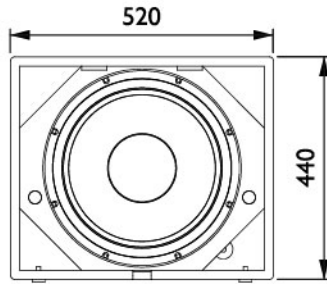

FRONT

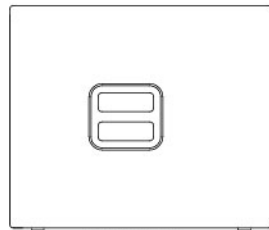

LEFT SIDE

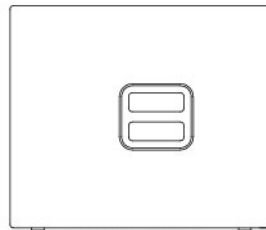

RIGHT SIDE

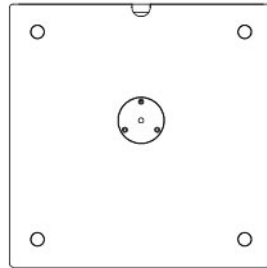

BOTTOM

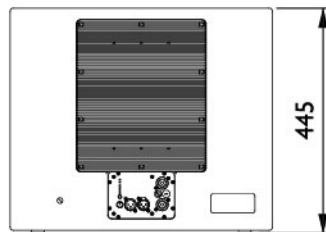

REAR

SCALE 1:15

(Dimensions in mm)

Figure 29: SB15P Line Drawing

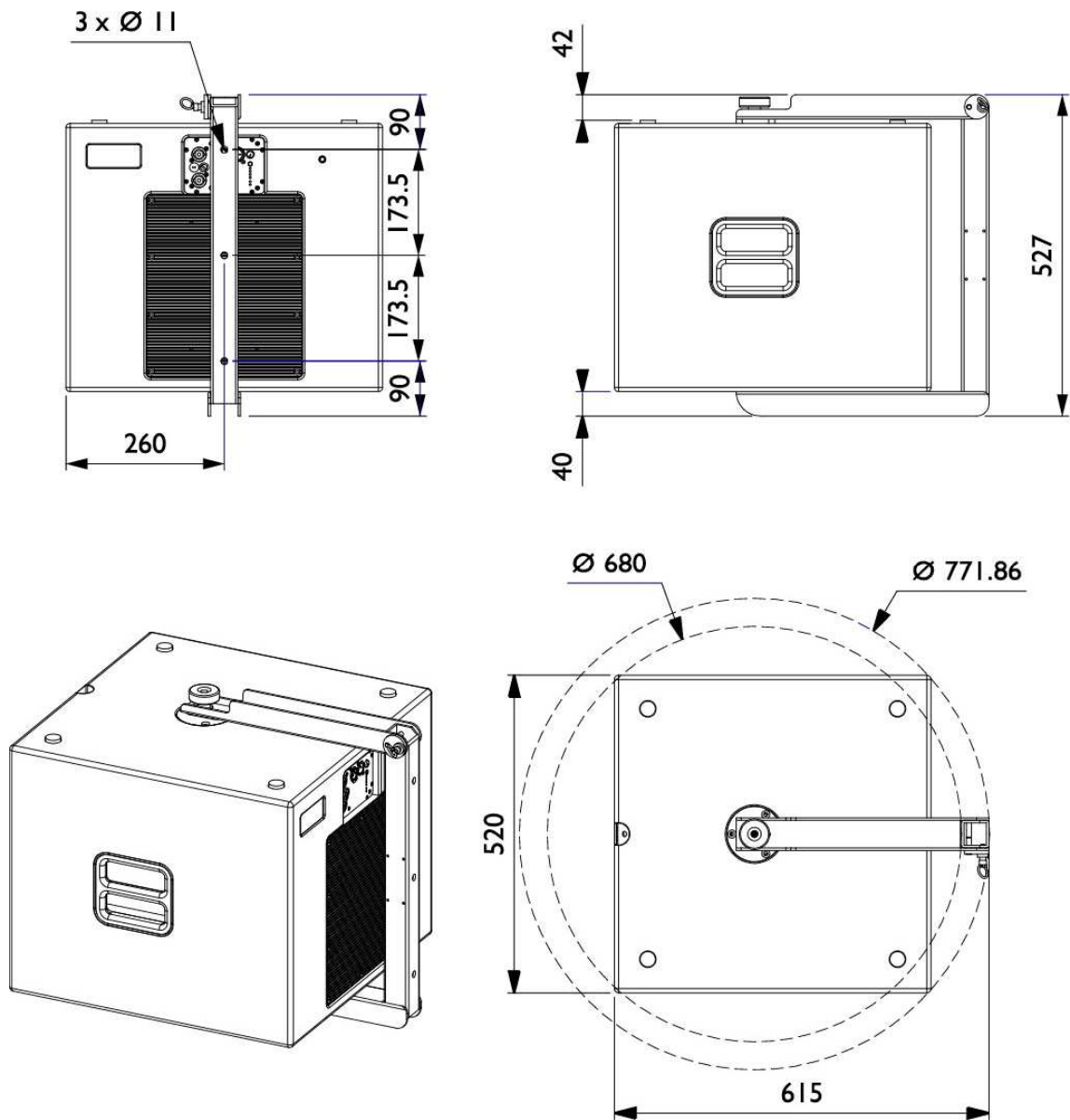

Figure 30: SBI 15P + ETRI 15P Line Drawing

WARRANTY AND DISCLAIMERS

This product is warranted to be free from defects in components and factory workmanship under normal use and service for a period of 3 years from the date of original purchase.

During the warranty period, L-ACOUSTICS or its nominated agents will undertake to repair, or at its option, replace this product at no charge to its owner if it fails to perform as specified, provided that the unit is returned undamaged and shipped pre-paid to the factory or an authorised service facility.

No other warranty is expressed or implied.

This warranty shall be null and void if the product is subjected to:

- 1) Repair work or alteration by persons other than those authorised by L-ACOUSTICS or its agents.
- 2) Operation with incorrect AC voltage.
- 3) Shipping accidents, war, civil insurrection, misuse, abuse, operation with faulty associated equipment or abnormal wear and tear. Units on which the serial number has been removed or defaced will not be eligible for warranty service.
- 4) L-ACOUSTICS will not be responsible for any incidental or consequential damages with respect to the products warranted.

L-ACOUSTICS reserves the right to make changes or improvements in the design or manufacturing without assuming any obligation to change or improve products previously manufactured.

FACTORY SERVICE

In the event that your L-ACOUSTICS product needs factory service, contact the L-ACOUSTICS service department for return instructions and a Return Authorisation number.

Please note when returning products for service:

1. Use the original packing
2. Include a copy of the sales receipt, your name, return address, phone number, fax number and a description of the defect.
3. Mark the Return Authorisation number on the outside of the packing.
4. Ship the product prepaid to:

INTERNATIONAL:
L-ACOUSTICS
Attention : SAV
Parc de la Fontaine de Jouvence
91462 Marcoussis
France

Telephone: +33 (0)1 69 63 69 63
Fax: +33 (0)1 69 63 69 64
E-mail: info@l-acoustics.com

NORTH AMERICA:
L-ACOUSTICS US
Attention : After Sales Service
2201 Celsius Avenue, Unit E
Oxnard, CA
93030 USA

Telephone: +1 (805) 604 0577
Fax: +1 (805) 604 0858
E-mail: info@l-acoustics-us.com



DECLARATION OF EC CONFORMITY

For the product:

Catalog Item: I08P

Description: L-ACOUSTICS® I08P
loudspeaker enclosure

Dimensions: 421 mm x 250 mm x 299 mm
(H x W x D)

Material: Baltic birch plywood
with external steel rigging plates

Optional accessories:
Rigging accessory – ETR8-2

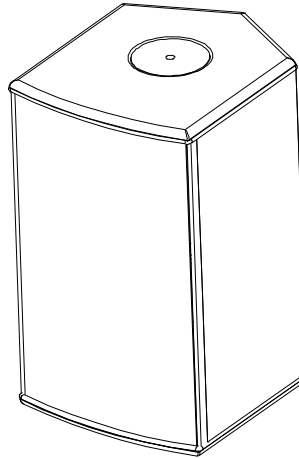

Product Origin

Country of origin of the product: France

Country of origin for components of the product: EEC

Standards conformity

L-ACOUSTICS hereby declares that the I08P loudspeaker conforms to :

1. **The Machinery Directive 98/37/CE**, Part 4 : Lifting Accessories
2. **Low Voltage Directive 73/23/CE** (harmonized standard EN60065).
3. **Electromagnetic Compatibility Directive 89/336/CE** (harmonized standard EN55103-1 E3 and EN55103-2 E3)

Established at Marcoussis, France, on the 4th of May, 2006

Signature of L-ACOUSTICS representative :

Jacques Spillmann
Chief Engineer - Manufacturing



DECLARATION OF EC CONFORMITY

For the product:

Catalog Item: ETR8-2

Description: L-ACOUSTICS® ETR8-2
rigging accessory

Dimensions: 485 mm x 225 mm x 50 mm
(H x W x D)

Material: Steel

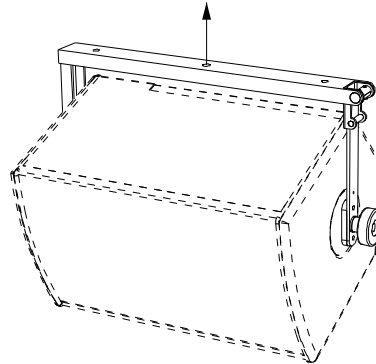

Product Origin

Country of origin of the product: France

Country of origin for components of the product: EEC

Technical Specifications:

The ETR8-2 rigging accessory is intended for overhead suspension (horizontal or vertical orientation) of MTD108a or 108P loudspeakers only. The following chart indicates the safety factor when using the ETR8-2 rigging accessory with MTD108a or 108P loudspeakers according to the conditions described in the L-ACOUSTICS MTD LINE OPERATOR MANUAL or the L-ACOUSTICS P SERIES OPERATOR MANUAL :

	ETR8-2
Weight	1.9 Kg / 4.2 lbm
WLL	13 daN / 29.2 lbf
Ultimate Strength	> 10
Safety Factor	

Standards conformity

MTD108a or 108P loudspeaker enclosures are designed to be suspended using the rigging accessory ETR8-2 in the horizontal or vertical orientation. The ETR8-2 can be attached to an appropriate support using 1, 2 or all 3 of the 9 mm diameter holes on the main bracket, refer to the appropriate operator manual for detailed mounting instructions.

L-ACOUSTICS hereby declares that the ETR8-2 conforms to:

4. **The Machinery Directive 98/37/CE**, Part 4: Lifting Accessories

Established at Marcoussis, France, on the 4th of May, 2006

Jacques Spillmann, Chief Engineer - Manufacturing



DECLARATION OF EC CONFORMITY

For the product:

Catalog Item: I12P

Description: L-ACOUSTICS® I12P
loudspeaker enclosure

Dimensions: 540 mm x 416 mm x 390 mm
(H x W x D)

Material: Baltic birch plywood
with external steel rigging plates

Optional accessories:
Rigging accessory – ETRI12XT
Rigging accessory – XTLIFTBAR

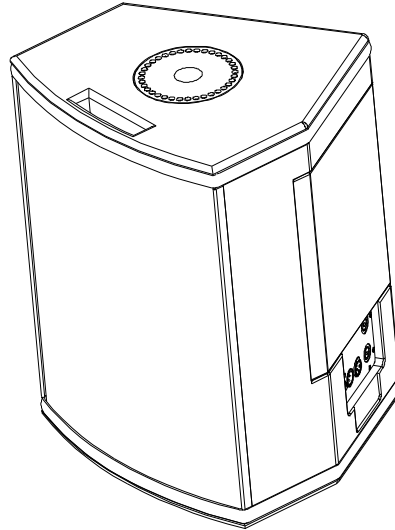

Product Origin

Country of origin of the product: France

Country of origin for components of the product: EEC

Standards conformity

L-ACOUSTICS hereby declares that the I12P loudspeaker conforms to :

5. **The Machinery Directive 98/37/CE**, Part 4 : Lifting Accessories
6. **Low Voltage Directive 73/23/CE** (harmonized standard EN60065).
7. **Electromagnetic Compatibility Directive 89/336/CE** (harmonized standard EN55103-1 E3 and EN55103-2 E3)

Established at Marcoussis, France, on the 4th of May, 2006

Signature of L-ACOUSTICS representative :

Jacques Spillmann
Chief Engineer – Manufacturing



DECLARATION OF CE CONFORMITY

For the product:

Catalog Item: ETRI 112XT
Description: L-ACOUSTICS® ETRI 112XT
Rigging accessory
Dimensions: 630 mm x 320 mm x 54 mm
Material: Steel

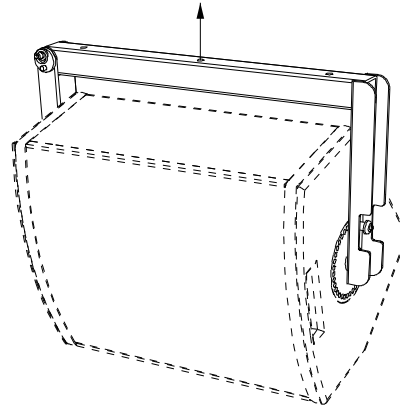

Product Origin

Country of origin of the product: France
Country of origin for components of the product: EEC

Technical Specifications :

The ETRI 112XT rigging accessory is intended for overhead suspension (horizontal or vertical orientation) of 112XT or 112P loudspeakers. The following chart indicates the safety factor when using the ETRI 112XT rigging accessory according to the conditions described in the L-ACOUSTICS XT LINE OPERATOR MANUAL or

L-ACOUSTICS P SERIES OPERATOR MANUAL:

	ETRI 112XT
Weight	5.25 Kg / 11.6 lbm
WLL	56.5 daN / 127 lbf
Ultimate Strength Safety Factor	> 12

Standards conformity

The ETRI 112XT is designed for the suspension of one 112XT or 112P loudspeaker enclosures only. The ETRI 112XT can be attached to an appropriate support using 1, 2 or all 3 of the 11 mm diameter holes on the main bracket, refer to the appropriate operator manual for detailed mounting instructions.

L-ACOUSTICS hereby declares that the ETRI 112XT conforms to :

8. The Machinery Directive 98/37/CE, Part 4 : Lifting Accessories

Established at Marcoussis, France, on the 4th of May, 2006

Jacques Spillmann, Chief Engineer - Manufacturing



DECLARATION OF EC CONFORMITY

For the product:

Catalog Item: XTLIFTBAR

Description: L-ACOUSTICS® XTLIFTBAR
rigging accessory

Dimensions: 180 mm x 79 mm x 46 mm
(H x W x D)

Material: Steel

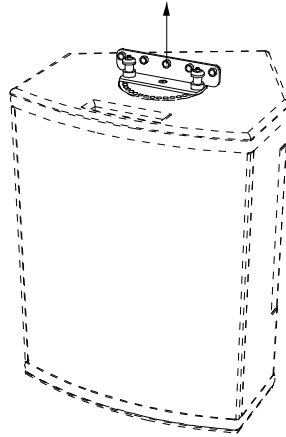

Product Origin

Country of origin of the product: France

Country of origin for components of the product: EEC

Technical Specifications :

The XTLIFTBAR rigging accessory is intended for overhead suspension (vertical orientation) of 112P, 112XT or 115XT loudspeakers. The following chart indicates the safety factor when using the XTLIFTBAR rigging accessory according to the conditions described in the L-ACOUSTICS XT LINE OPERATOR MANUAL or

L-ACOUSTICS P SERIES OPERATOR MANUAL:

	XTLIFTBAR
Weight	0.55 Kg / 1.2 lbm
WLL	33 daN / 73 lbf
Ultimate Strength Safety Factor	> 10

Standards conformity

The XTLIFTBAR is designed for the vertical suspension of 1 x 112P, 112XT or 115XT loudspeaker only, refer to the appropriate operator manual for detailed mounting instructions.

L-ACOUSTICS hereby declares that the XTLIFTBAR conforms to :

9. **The Machinery Directive 98/37/CE**, Part 4 : Lifting Accessories

Established at Marcoussis, France, on the 4th of May, 2006



DECLARATION OF EC CONFORMITY

For the product:

Catalog Item: SBI5P
Description: L-ACOUSTICS® SBI5P
loudspeaker enclosure
Dimensions: 445 mm x 520 mm x 520 mm
(H x W x D)
Material: Baltic birch plywood
with external steel rigging plates

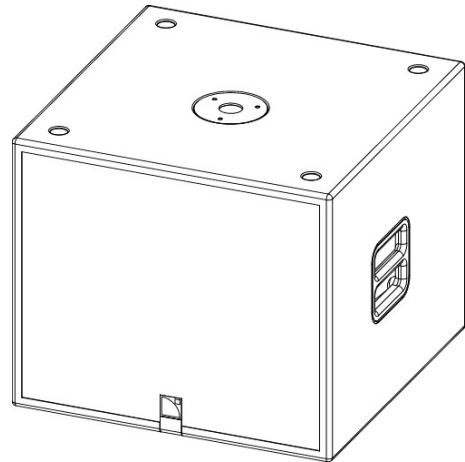

Optional accessories:

Rigging accessory – ETRI5P

Product Origin

Country of origin of the product: France

Country of origin for components of the product: EEC

Standards conformity

L-ACOUSTICS hereby declares that the SBI5P loudspeaker conforms to :

10. **The Machinery Directive 98/37/CE**, Part 4 : Lifting Accessories
11. **Low Voltage Directive 73/23/CE** (harmonized standard EN60065).
12. **Electromagnetic Compatibility Directive 89/336/CE** (harmonized standard EN55103-1 E3 and EN55103-2 E3)

Established at Marcoussis, France, on the 4th of May, 2006

Signature of L-ACOUSTICS representative :

Jacques Spillmann
Chief Engineer – Manufacturing



DECLARATION OF CE CONFORMITY

For the product:

Catalog Item: ETRI5P
Description: L-ACOUSTICS® ETRI5P
Rigging accessory
Dimensions: 527 mm x 415 mm x 60 mm
Material: Steel

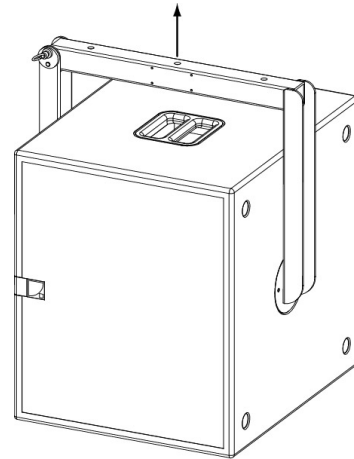

Product Origin

Country of origin of the product: France
Country of origin for components of the product: EEC

Technical Specifications :

The ETRI5P rigging accessory is intended for overhead suspension (horizontal or vertical orientation) of the SB15P loudspeaker. The following chart indicates the safety factor when using the ETRI5P rigging accessory according to the conditions described in the L-ACOUSTICS P SERIES OPERATOR MANUAL:

	ETRI5P
Weight	5.3 Kg / 11.7 lbm
WLL	36 daN / 80.9 lbf
Ultimate Strength Safety Factor	> 12

Standards conformity

The ETRI5P is designed for the suspension of one SB15P loudspeaker enclosure only. The ETRI5P can be attached to an appropriate support using 1, 2 or all 3 of the 11 mm diameter holes on the main bracket, refer to the P Series Operator manual for detailed mounting instructions.

L-ACOUSTICS hereby declares that the ETRI5P conforms to :

13. The Machinery Directive 98/37/CE, Part 4 : Lifting Accessories

Established at Marcoussis, France, on the 4th of May, 2006

Jacques Spillmann, Chief Engineer - Manufacturing

APPROVALS

 This equipment conforms to the requirements of Low Voltage Directive 73/23/EEC and the EMC directive 89/336/EEC.

This equipment also conforms to the following standards:

EMC Emission	EN55103-1, E3
EMC Immunity	EN55103-2, E3
EMC	47 CFR FCC Part 15 of 2005
EMC	CISPR 13 of 2003
Electrical Safety	EN60065, Class I

 For 115V use only
C US

CAN/CSA 60065-03 - Audio, Video and Similar Electronic Apparatus - Safety Requirements.

UL Std No. 60065-03 - Audio, Video and Similar Electronic Apparatus - Safety Requirements.